

SUSTAINABLE

Concrete Masonry

Assuring a healthy future one block at a time



C o n c r e t e M a s o n r y U n i t s

A r c h i t e c t u r a l C o n c r e t e B l o c k

C o n c r e t e B r i c k

S e g m e n t a l R e t a i n i n g W a l l s

C o n c r e t e G r i d P a v e r s

A r t i c u l a t e d C o n c r e t e B l o c k



Concrete Building Blocks for

Sustainable Building with Concrete Masonry

From the early days of concrete masonry, right up to the present, those who understood the energy efficiency, durability, and natural aesthetics of concrete masonry have realized that it doesn't take special efforts to make concrete masonry environmentally friendly...it is a natural building material with unparalleled environmental qualities. And concrete masonry has the flexibility to be adapted to specific needs.

Concrete masonry producers are eager to demonstrate how these qualities can contribute to practical designs, enduring structures and environmental responsibility. Sustainability is about building the quality of life for now and future generations. This concept includes improving occupant well-being, mitigating environmental impacts, and providing reasonable economic returns on investment. Using green building practices can result in energy and cost savings over the life of the structure. Occupants of green buildings enjoy improved indoor air quality and day-lit spaces, improved health, comfort and productivity.



Sustainable Sites

Concrete landscape products -

- Do not require large equipment for delivery or placement, nor large staging areas for construction
- Reduce storm-water runoff with permeable concrete pavers
- Support grass or other plant growth in open cell concrete products
- Reduces development footprint through use of comparatively smaller delivery and placement equipment and smaller staging areas for construction

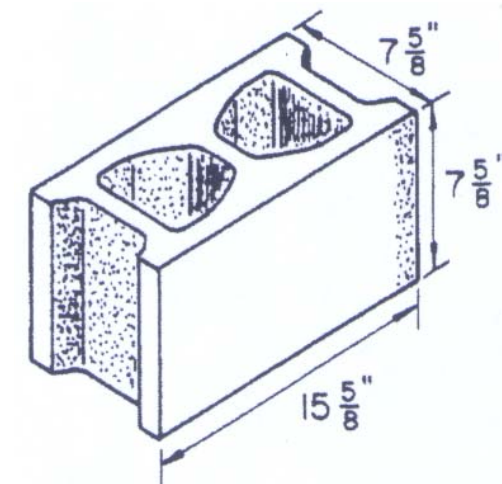

Indoor Environmental Quality

Concrete masonry -

- Improves indoor air quality by eliminating the need to paint, thus reducing associated volatile organic compounds, when architectural or prefaced concrete masonry units are chosen
- Reduces the potential for mold growth because concrete masonry does not provide a ready food source for mold

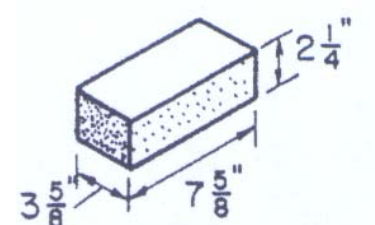

Sustainable Development



Innovation and Design Process

Concrete masonry -

- Improves environmental impacts through life-cycle considerations
- Improves fire safety for occupants and property
- Improves acoustical performance



Energy and Atmosphere

Concrete masonry -

- Provides high thermal mass and specific heat, and therefore thermal storage, compared to frame wall construction
- Remains warm or cool long after the heat or air-conditioning has shut off, reducing heating and cooling loads
- Improves occupant comfort by moderating indoor temperature swings
- Shifts peak heating and cooling loads to off-peak hours

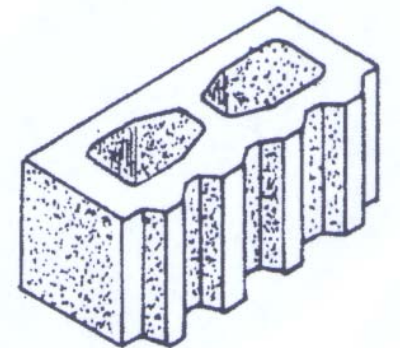

Materials and Resources

Concrete masonry and concrete landscape products-

- Made from abundant local raw materials
- Manufactured close to construction sites, minimizing fuel requirements for handling and transportation
- Able to be produced using recycled aggregates and cementitious materials

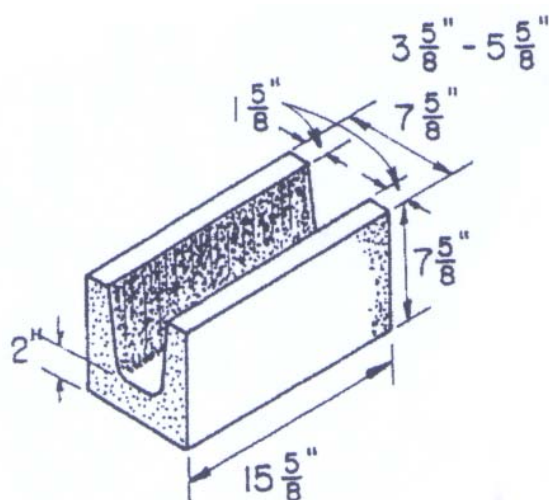

For more information, click or call NCMA today!

703.713.1900 • www.ncma.org

Environmental Responsibility: A Long-Time Mainstay of the Concrete Masonry Industry

Since 1918, the National Concrete Masonry Association has represented those involved in the production of concrete masonry. Concrete masonry producers have long provided a wide assortment of building components that contribute to safe and sustainable construction.

Concrete Masonry Units
Architectural Concrete Block
Concrete Brick
Segmental Retaining Walls
Concrete Grid Pavers
Articulated Concrete Block



The NCMA Education and Research Foundation is a member of The U.S. Green Building Council (USGBC), the nation's foremost coalition of leaders from across the building industry working to promote buildings that are environmentally responsible, profitable and healthy places to live and work.

The LEED (Leadership in Energy & Environmental Design) Green Building Rating System is a voluntary standard that defines high performance green buildings which are healthier, more environmentally responsible and more profitable structures. For the concrete masonry industry, participation in the LEED Rating System development process is important because concrete masonry has many inherent attributes that fit the model being shaped by USGBC members.

The NCMA Education and Research Foundation advances and supports the concrete masonry industry and the public interest through research and education programs designed to meet the future needs of the industry. Membership in the USGBC is in alignment with the concrete masonry industry's mission and means that the concrete masonry industry is better positioned to forge strategic alliances with key industry and research organizations to more clearly identify and enable research that will transform the built environment toward a more sustainable future.

National Concrete Masonry Association
FOUNDATION